

Gas Holder Balloon

UniRub Techno India Pvt. Ltd. a proven name in the field of operationally critical and high tech rubber products have successfully designed, developed and manufactured the UTIPL gas holder balloon for industrial applications.

Gas holder balloon is fabricated out of high tenacity polyamide fabric matrix coated with compatible polymer based on the application requirement on the inside & the outer side is coated with hypalon for weather abrasion and UV resistance.

As an industrial gas holder balloon manufacturer, we take pride in providing high-quality and reliable solutions for gas storage and transportation. Our gas holder balloons are designed to handle a wide range of industrial gases, including but not limited to:

- Syngas, or synthesis gas
- Nitrogen
- CO₂ (Carbon Dioxide)
- Oxygen
- Biogas
- Nitrous Oxide (N₂O)
- Hydrogen
- Various other industrial gases

Our gas holder balloons are engineered with safety, durability, and efficiency in mind. They are capable of withstanding a maximum working pressure of 0.65 PSI, ensuring the secure containment of gases under various operating conditions.

As an industrial gas holder balloon manufacturer, our versatile products find applications in a wide range of industries and processes. Some key applications of our gas holder balloons include:

1. Energy Production
2. Chemical Industry
3. Oil and Gas Sector
4. Biogas Production
5. Transportation

Unirub Techno India Pvt. Ltd.

We provide a standard range of our gas holder balloon as follows.

Sr. No.	UTIPL No.	Dimeter (mtr)	Height (mtr)	Volume (m3)
1	UTIPL GB01	1.28	2.40	3
2	UTIPL GB02	1.46	3.00	5
3	UTIPL GB03	1.74	3.00	7
4	UTIPL GB04	2.10	3.00	10
5	UTIPL GB05	2.91	3.00	20
6	UTIPL GB06	3.00	3.60	25
7	UTIPL GB07	3.20	3.75	30
8	UTIPL GB08	3.50	3.65	35
9	UTIPL GB09	3.55	4.00	40
10	UTIPL GB10	4.00	4.00	50
11	UTIPL GB11	4.47	4.80	75
12	UTIPL GB12	5.00	5.10	100
13	UTIPL GB13	6.52	6.00	200
14	UTIPL GB14	7.14	10.00	400

We understand that different industries have unique requirements, so we also offer customizable solutions to meet your specific needs. Whether you need gas holder balloons for energy production, chemical manufacturing, transportation, or other applications, we have the expertise to deliver tailored products that match your requirements.

Contact us

Email : unirubtechno@gmail.com

Phone: +91 8799906199

Unirub Techno India Pvt. Ltd. Gat No. 354/355/364, At Post Takwe Budruk, Taluka Maval, Dist. Pune 412106. <https://unirubpune.co.in/>



UniRub
Techno India Pvt. Ltd.



BALLOON GAS HOLDER

Unirub Techno India Pvt. Ltd. a proven name in the field of operationally critical and high - tech Rubber Products has successfully designed, developed and manufactured the UTIPL Gas Holder Balloon for Industrial Gas Manufacturers.

This Gas Holder Balloon is fabricated out of high tenacity polyamide fabric matrix, impregnated with compatible polymer on the inside with hypalon for weather abrasion and UV resistance.

This Gas Holder Balloon is a collapsible, intermediate storage tank for any Industrial Gas, prior to bottling under pressure.

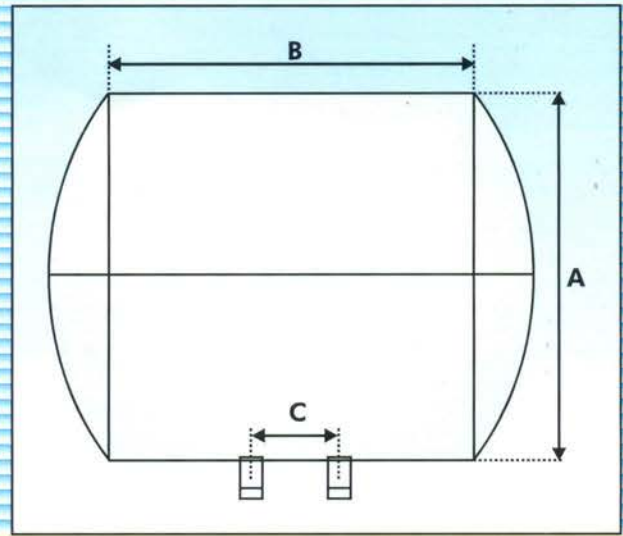

ADVANTAGES :

The distinct advantages of this type of Gas Holders are

1. Being manufactured out of very tough rubbersied fabric it is collapsible and very light weight and is installed hanging just below the ceiling, saving valuable floor space and is tailor made to suit the available space and capacity.
2. Being fabric, it does not corrode (like the metal tank) and as such it is maintenance free, giving it a long, trouble free life.

The UTIPL Gas holder balloon eliminates the use of the conventional metal tank, currently used as intermediate storage.

Capacity	A	B	C	D
5 M ³	1460	3000	750	80
10 M ³	2200	3000	750	80
25 M ³	3050	3600	750	115
50 M ³	4000	4000	1000	205
75 M ³	4500	4800	1000	205
100 M ³	5000	5100	1500	205



Webbing



















